

IIMN/154/2021-22/15 dated 21/03/2022



IIM NAGPUR

भारतीय प्रबंध संस्थान नागपुर
Indian Institute of Management Nagpur

INDIAN INSTITUTE OF MANAGEMENT NAGPUR



TENDER DOCUMENT

**Supply, installation and commissioning of LOT type Gas bank system
for S&F Dining block, EEP Dining block at IIM Nagpur,
MIHAN campus.**

Part-1 Technical bid

Client

CAO

Indian Institute of Management Nagpur – 440010

Email : purchase@iimnagpur.ac.in

Phone no. 7030937782,7875832307



NOTICE INVITING TENDER (Offline mode)

Tender no: Ref. No. IIMN/154/2021-22/15 dated 21/03/2022

1. Bids are invited under two bid system for **Supply, commissioning and installation of LOT type Gas Bank for S&F Dining block & EEP Dining block** for Indian Institute of Management Nagpur (hereinafter to be referred as "IIMN") at MIHAN Campus, MIHAN, Nagpur. The bids are to be submitted in a sealed envelope as per the timelines below.

The details of tender notification, technical bid and financial bid can be downloaded at

<https://www.iimnagpur.ac.in/tenders>

Bid Publishing Date	21/03/2022
Prebid meeting	28/03/2022; by 11.00 AM
Last date of Bid Submission	11/04/2022; by 11.00 AM
Technical Bid Opening Date	11/04/2022; at 11.30 AM
Financial Bid Opening Date – Price Bids of only those bidders whose Technical Bids are complete in all respects will be opened.	11/04/2022; at 03.00 PM (May be changed if technical bid evaluation is delayed)

2. Bid Submission:

All pages of tender documents (downloaded from IIMN website) shall be stamped, signed and physically submitted by the bidder in TWO sealed envelopes in the sequence given below:

Envelope – 1 (Technical Bid)	Bid Security Declaration, Mandatory and Pre-qualification Bid document, Tender document signed and stamped on each page, Technical Bid
Envelope – 2 (Price Bid)	Original Price Bid document signed and stamped on each page shall be submitted. The bidder has to fill the price in the Price bid format downloaded from IIMN website only. The prices shall be filled both in figures and in words and the total amount shall be calculated and rounded off to the nearest rupee. No overwriting or use of correction fluid shall be accepted. Any correction shall be legible and signed by the authorised signatory.

The tender shall be submitted in two parts, viz., technical bid and price bid. The offers submitted by Fax/email shall not be considered. No correspondence will be entertained in this matter Sealed Bids (with the Tender No. clearly written on the envelopes) should reach at the below address before the last date of Bid submission:

To,
Indian Institute of Management Nagpur
Plot No-01, Sector-20, MIHAN Notified area,
Dahegaon Khapri (Rly), Nagpur-441108

Issued by
Chief Administrative officer
Indian Institute of Management Nagpur
Ph. No 7030937782,787583230

**Chapter - 1 Technical bid**

Sealed tenders are invited from bonafide, experienced & reputed contractors of financial standing for the job given below:

Clause No.	Title	Description
101	Name of work	Supply, installation and commissioning of LOT type Gas bank system for S&F Dining block, EEP dining block at IIM Nagpur, MIHAN campus.
102	Tender no.	Tender no: IIMN/154/2021-22/15 dated 21/03/2022
103	Details of bidder	Annexure- A is to be filled, duly signed and stamped and upload along with the tender.
104	Tender fees submission cost	Nil
105	Earnest Money Deposit (EMD)	A Bid Security Declaration is to be submitted by the bidder in lieu of EMD. The format (Attached as Annexure B) shall be printed on the bidder's letterhead, signed and stamped by the authorized signatory and submitted with the PQ & Technical Bid.
106	Contract Period	60 days from the date of issue of work order OR date of approval by Engineer in charge (Whichever is later). Extendable for the reasons beyond contractor's control and upon Engineer's recommendation.
107	Liquidated Damage	Delivery shall be considered complete when full quantities of all items are in fully functional condition at designated delivery location as per the instruction of the representative of IIMN. For late delivery (LD) the liquidity damage shall be @1% of the contract amount per week delay. Maximum up to 5%. Beyond 5 weeks of delay in delivery, the order will be deemed cancelled.
108	Initial Security Deposit (ISD)	NA
109	Performance Security Deposit	Successful bidder has to submit Performance Security Deposit (PSD) @ 3% of the contract value. It should be deposited within two weeks from the date of award of contract in the form of DD/Bank guarantee from a scheduled commercial bank in favour of " Indian Institute of Management Nagpur ". If any amount remains liable to be recovered by IIMN from the bidder or in the event of termination of contract by IIMN on account of breach of any terms and conditions of the contract by the bidder, the PSD shall be invoked by IIMN.
110	Release of RSD	NA
111	Release of ISD/PSD	PSD amount will be released after successful completion of Defect Liability Period.
112	Interest on Security Deposit	No interest will be paid on any deposit



IIM NAGPUR

भारतीय प्रबंध संस्थान नागपुर
Indian Institute of Management Nagpur

113	Defect Liability Period	12 months from the date of completion of the work certified by IIMN Engineer-in -charge.
119	Conditional Bids	Conditional bids or Bids based on the process / basic schemes other than mentioned and / or not conforming to the technical specifications / requirements of the Bidding documents will not be considered.
120	Contract Agreement	IF REQUIRED BY Indian Institute of Management Nagpur (hereinafter to be referred as IIMN), the successful Bidder has to execute a contract Agreement with IIMN on the non-judicial stamp paper of Rs. 100/- (Rupees One hundred only). The cost of stamp paper shall be borne by successful Bidder. IIMN reserves the right to amend the terms & conditions of contract after Mutual discussions and shall only be in writing.
121	Insurance	The contractor shall take adequate insurance covering risk for material and labor, general public liability/third party liability & workmen compensation insurance coverage suitable to the type of work, work order amount, contract period. Copy to be submitted to IIM Nagpur. In case of any mishap, the liability for the same will be borne by the Contractor & not Involve IIMN. The Contractor has to take an insurance policy accordingly.
122	Work and risk cost	The Institute reserves the right to get the whole or part of the work executed by some other agency at the risk and cost of the contractor if it is found that the quality and/or the progress in respect of whole or part of the work is not satisfactory.
123	Indemnity	The Contractor shall indemnify and keep indemnified the Institute against all losses and claims for injuries and or damages to any person or property. The contractor shall abide by and observe all statutory laws and regulations in matters of Labor Law, Factory Act, Explosive Act, Workmen Compensation Act, Sales Tax, Royalty, Excise Duty, Octroi, Works Contract, etc. and shall keep the Institute indemnified against all penalties and liabilities of every kind for breach of any such statute ordinance or law/regulations or By laws. The Contractor shall not employ child labour. Payment to workers must be according to Minimum wages act.
124	Compliance with owners rules and regulations	The Contractor shall comply with all norms stipulated by the IIMN such as Gate Passes, Checking, Maintenance of Cleanliness, Discipline & Decency at and Around the work site, Safety Precautions and Safety Regulations.
125	Arbitration	If any dispute, difference, controversies or claims of any kind whatsoever shall arise between IIMN and the successful bidder, they shall seek to resolve any such dispute or difference by amicable mutual consultation and deliberation in good faith within 21 days from the date of intimation of such dispute, difference, controversies or claims by referring it to the Director of IIMN by the successful bidder. If IIMN and successful bidder fail to resolve such dispute or difference, controversy, or claim by mutual consultation, then either Party may



IIM NAGPUR

भारतीय प्रबंध संस्थान नागपुर
Indian Institute of Management Nagpur

		give the other, a formal notice in writing that the dispute, difference, controversy or claim exist specifying its nature, the point(s) in issue and its intention to refer such disputes, differences, controversies, or claims to arbitration under the Arbitration and Conciliation Act, 1996. The sole arbitrator shall be appointed by Director IIMN having requisite technical expertise to adjudicate such nature of disputes. The decision of sole arbitrator shall be binding on both the parties. Arbitration shall be held in Nagpur, India and the arbitration proceedings shall be conducted in the English language. The arbitrator will be requested to give their award in 60 days' time. The award shall be a reasoned award and the same shall be final and binding on the Parties. The award shall be entered in the courts at Nagpur and such courts may order enforcement of the award against the Parties and their respective successors and permitted assignees. The costs and expenses of the arbitration shall be borne by equally by both the parties. The courts in Nagpur shall have the exclusive jurisdiction.
126	Authorization	The Contractor shall submit to the Institute the names and reason and specimen signatures of the persons authorized by him to draw materials, sign joint measurements, bills, receive payments, receive instructions/notices, etc. on behalf of the Contractor.
127	Safety and Security	Contractor shall abide by the safety code provisions as per safety code framed from time to time by the government.
128	Prices, Taxes & Duties	The Bidder should quote firm prices/ rates inclusive of all Taxes Duties, Levies, Personal Tax, Corporate Tax, Welfare cess, irrespective of height, depth, lead, lift etc. The rates shall include cost of all materials, labor, machinery, transit insurance and all other inputs involved in the execution and all scope of work including terms & conditions
129	Bid Validity	The bid submitted by bidder shall remain valid for a period of 6 Months from the date of opening of Price bid. Bidder shall not be entitled during this period to revoke or vary the content of Bid or any term thereof. In such case of making any variation subsequent to submission of bid at their own, the offer shall be treated as "REJECTED."
130	Award of similar type of work on same rates	Upon mutual consent, the client may award another similar type of works/services in campus based on this rates to the contractor, for which the rates may be valid up to ONE year from the date of issue of Work order.
131	Access to site	The Contractor shall allow unhindered access to the Institute and/or any other party or person, engaged by the Institute to work at the same site and/or to check/ regulate / watch /guard/ measure/inspect, solely or jointly with the Contractor.



132	Rejection of bid(s)	IIMN reserves the right to, at any time and in its absolute discretion the following
		i) Accept or reject any or all bids
		ii) To permit any bidder to resubmit its shortfall documents
		iii) To negotiate the price with L-1
		iv) To suspend, discontinue, modify and/or terminate the Tendering process at any time without assigning any reason whatsoever
133	Quantum of work	This contract is basically a Lump sum contract. The quantities given in the "Annexure are approximate only and may vary in actual course of execution. The BIDDER is therefore, advised to quote very carefully. No claim for compensation from the Contractor shall be entertained due to any variation in quantities (irrespective of the quantum of variation) OR deletion of any item. The rates will be applicable to other similar works in the campus as and when required by IIMN.
134	Assignment and sub-contracting	The Contractor shall not assign, sub-contract or sub-let the whole or any part of the contract in any manner. In case of on unavoidable circumstances, the contractor shall be able to do it with approval of the owner of premises. However, the job shall be sublet only to the party approved by the IIMN.
135	Misconduct	The contractor shall keep the IIMN indemnified from and against all personal and third party claims whatsoever arising out of any commission or omission by contractor or his employees, or representatives as the case may be
136	Inspection, & quality check by IIM-Nagpur	The IIMN shall be entitled to inspect the Contractor materials use for packing of equipment. If any material, item or component intended to be used for the work is found to be unsatisfactory (in which matter the decision of the IIMN or his authorized representative shall be final), the Contractor shall not use such material.
137	Interpretation	The Special conditions of Contract shall be read in conjunction all other documents forming of this contract. Notwithstanding the sub-divisions of the documents into these separate sections, every part of each shall be deemed to be supplementary to and complimentary of every part and shall be read with and into the contract.
138	Vacation of the premises	The Contractor shall give vacant possession of the facilities/premises made available to the Contractor by IIM-Nagpur.
139	Water	Free of Cost at one point by IIM-Nagpur
140	Electricity	Free of Cost at one point by IIM-Nagpur



141	Payment of Bills	Payments will be made by e – payment or RTGS/NEFT after successful completion of Work as per payment schedule.
141.1	Payment Schedule	<ol style="list-style-type: none"> 1. 1st Running Bill – 10% of the total contract amount - On delivery of material at site after physical inspection and original purchase invoice. 2. Final Bill – 90% of the total contract amount - On completion of work, inspection and clearance of site
		Payments will be made within 15 days of submission of bills provided the bills are complete and duly authenticated by the specified Officer(s) of IIMN as applicable to this service as per payment schedule
142	Escalation / De-escalation of rates	Prices/Rates quoted will be firm during the entire duration of contract
143	Basic Rates	Not Applicable
144	Non tender items/ Extra Items	Not Applicable
145	Method of Measurement	Not Applicable
146	Termination	
146.1	Termination due to contractor's Default	<p>If the contractor is in default under any of the provisions of this Contract, including but not limited to:</p> <ol style="list-style-type: none"> a. failure to proceed with all or any part of the Contract or Contract Work with due diligence, b. failure to execute all or any part of the Contract or to perform any other obligations in accordance with the Contract. c. refusal or neglect to make good defective Work or after being instructed to do so by IIMN. d. going into liquidation (other than a voluntary liquidation for the purpose of reconstruction) or having a receiver appointed for all or part of its undertaking. e. delay in executing the Contract f. abandoning the Contract g. assigning or subletting any part of the Contract Scope of Work without the prior written approval of IIMN; h. failure to comply with any Applicable Law; <p>then, and in any such event and without prejudice to any other rights or remedies that IIMN may have, IIMN may issue contractor written notice describing the default. If contractor does not commence remedy of the default within (10) Ten days after receipt of the notice, IIMN may terminate all or any part of the Contract</p>



		<p>Work under this Contract and may then complete or have others complete all such terminated Work at the contractor's sole risk and cost.</p> <p>In case of such termination, contractor shall not be entitled to receive further payment, until the terminated Work is completed and accepted by IIMN. If the costs incurred by IIMN, including costs incurred in performing additional services to complete the Contract Scope of Work and IIMN's overheads in this regard, exceed the unpaid balance of the Contract Price, the contractor shall reimburse IIMN such excess within (10) ten days after receipt of an invoice thereof.</p> <p>The rights and remedies provided in this Article are in addition to the rights and remedies provided to IIMN by law, equity, or under any other Article in this Contract.</p> <p>Such termination will not relieve the contractor of its responsibility to its labourers, suppliers or any other creditors, including IIMN.</p>
		<p>In the event of a termination under above Article, IIMN may use all or part of contractor's drawings, documents and facilities at Site, in the performance of the Contract Scope of Work, without payment to contractor otherwise than by the extent such use of contractor's items causes a reduction of cost of completing the Contract Scope of Work.</p>
146.2	Termination for Convenience	<p>IIMN may, at its opinion, terminate for convenience the Contract Scope of Work in whole or in part, at any time by written notice to contractor. Such notice shall specify the extent to which the performance of Work is terminated and the effective date of such termination. Upon receipt of such notice, contractor shall:</p> <p>a) Immediately discontinue the Contract Scope of Work on the effective date or date of receipt of notice from IIMN, whichever is the latest and to the extent specified in the notice and place no further orders or sub-Contracts for services, other than as may be required for completion of such portion of the Contract Scope of Work that is not terminated;</p> <p>b) Promptly obtain cancellation upon terms satisfactory to IIMN of all purchase orders, sub-Contracts, rentals, or any other agreements existing for the performance of the terminated Work or assign those agreements to IIMN as instructed;</p> <p>c) Assist IIMN in the maintenance, protection, and disposition of Work in progress, plant, tools, equipment, property, and Goods acquired by contractor or furnished by contractor under this Contract.</p> <p>d) Complete performance of the Contract Scope of Work that is not terminated.</p> <p>Upon any such termination for convenience, IIMN shall have no liability towards contractor for any damages, including loss of anticipated profits. As its sole right and remedy, contractor shall be paid for</p>



		<p>a) The Work, which has been satisfactorily performed till date of such termination. contractor shall have the responsibility to submit the Scope of Work that had carried out prior to the termination date with sufficient documentation within 7 days from date of the receipt of the termination notice. All such Scope of Work shall be properly protected and handed over to IIMN.</p> <p>b) All amounts due and not previously paid to contractor for Contract Scope of Work completed in accordance with the Contract prior to such notice of termination, and for Work thereafter completed as specified in such notice.</p> <p>The termination of the Contract shall not relieve the contractor of any continuing rights, obligations and liabilities under the Contract.</p>
147	Exit Clause	The vendor has to complete the works within the time schedule mentioned at clause No.106, and on failing to do so, the vendor shall be notified on expiry of such delivery schedule. Even after such notice, if the vendor fails to complete its work to its entirety and hand over the same to IIMN for its use within two weeks form the date of issue of such notice, the order/contract shall deemed to be cancelled without any further notice to the vendor. Notwithstanding anything in this clause, IIMN shall be at its liberty to impose LD/penalty as mentioned in clause no.107 on the vendor as it deemed fit. The vendor shall not be allowed to remove any material pertaining to incomplete work, and IIMN shall not be liable to make any payment for the incomplete work."
148	Force Majeure	If the whole of any part of the performance by the Parties of any part of their respective obligations hereunder is prevented or delayed by causes, circumstances or events beyond the control of the Parties including delays due to floods, fires, accidents, earthquakes, riots, explosions, wars, hostilities, acts of government, custom barriers, or other causes of like character beyond the control of the Parties, then to the extent the Parties shall be prevented or delayed from performing all or any part of its obligations hereunder by reason thereof despite due diligence and reasonable efforts to do so notwithstanding such causes, circumstances or events, the Parties shall be excused from performance hereunder for so long as such causes, circumstances or events shall continue to prevent or delay such performance. However, there will not be any additional cost implications towards IIMN for such delay in performance, and the successful bidder agrees to complete scope of service & meet his obligations under contract for the cost agreed in LOI/ Work order.
149	Taxes, Labor laws and Other regulations	The Contractor will be exclusively responsible to meet and comply with all legal requirements related to the work/services
149.1		
149.2		



		of any and all existing taxes of the Central or State Government or of any other authority with respect to the contract or any item sold or supplied pursuant thereto or anything done or service rendered pursuant thereto.
149.3		The Contractor/firm shall be responsible to abide by legal and labour provisions prescribed by the Government of India which shall include Income tax, Insurance, Accident, ESI, PF, Minimum Wages, Contract Labour R&A Act, etc.
149.4		Any legal matter or issues arise, and all court matters if arise for this contract are subjected in Nagpur courts jurisdictions only.
150	System of Bid Evaluation	Price BID of only those bidders who qualify in Technical bid/Eligibility criteria given will be opened.
151	Precedence Clause	In the case of any ambiguity in interpretation, the Price bid will supersede the Technical Qualification bid and decision by Asst. Manager (A&C), IIMN on the interpretation of the entire contract terms and conditions will be final and binding to all.
152	Mathematical error	During the opening of price bids the total quoted amount will be declared. However, during calculation verification if there is any error found in total amount, the agency will be called for clarifications. The rates quoted by the agency will be considered firm and hence the amount will be worked out by multiplying the rate with quantity. The rate will not be allowed to be changed in any case. However, decision by Asst. Manager (A&C), IIMN on the interpretation of the entire contract terms and conditions will be final and binding to all.



Chapter 2

Eligibility Criteria for Bidders:

Sr.	Description	Remarks (Documents to be attached)
1	Bidder must be authorized enlisted supplier/distributor/Installer of designated brands such as HPCL, IOCL and Equivalent PSU LPG supplier Agencies.	Please attach proof of authorized dealership.
2	Bidder must be in the business of supply of above similar work as per tender items in Scope of work for at least five years.	Please attach proof of establishment of business
3	The tenderer should have completed similar work in Central Government/ State Government Department (including Public Sector Undertaking / Autonomous bodies), Govt. Institutes/ Hospitals/ Private Institutes, Research Institutes, household, offices in last five years ending March 2021. Similar works means Supply and Installation of Gas Bank.	Agreement / Work order copy /completion certificate to be enclosed ONE similar work of single contract value not less than Rs 8 lakh. OR TWO similar works with each of single contract value not less than Rs 4 lakh OR THREE similar works with each of single contract value not less Rs 3.2 lakh
4	The annual turnover of the bidder in last three consecutive financial years as on 31.03.2021 (For FY 2018-19, 2019-20 & 2020-21) shall be minimum Rs: 10 lakh	Please attach Chartered Accountant's certificate / Signed copies of audited accounts Balance sheet & Profit and loss accounts) duly certified by the Chartered Accountant. Fill in Annexure C
5	Bidder should not have been blacklisted to supply from any government organization.	An undertaking on the Bidder's letterhead to that effect should be attached with the Technical Bid.

Desirable Conditions –

1. The bidder should have business and service team in Nagpur.



Chapter 3

Scope of Work

Supply, installation and commissioning of LOT type Gas bank system for S&F Dining block & EEP block at IIM Nagpur, MIHAN campus.

1. Designing of the LOT type Gas bank system as per the Kitchen Equipment layout compatible for 10+10 LPG commercial cylinders of 47.5 Kg for S&F Dining block and 5+5 LPG commercial cylinders of 47.5 Kg for EEP Dining block. Submission and Approval of schematic drawings from IIMN Authorities.
2. Supply installation and commissioning LOT type gas bank system.
3. Providing of Free service and maintenance of both gas banks for 1 year from date of completion of work (Labor and Visiting Charges will be free of cost). Charges of Consumables will be paid extra by IIMN.

Note: -Bidders are required to visit the site before bidding.

Indicative General Specifications of components of gas bank

Sr. No.	Particulars	Specifications	Sizes	Make
1	Manifold	Fabricated in 1"CS Sch 40 seamless pipe	Size: 1"	Fabricated
2	LOT Valve Adaptor	Forged, Brass. Suitable to LOT Valve and 3/8 BSP Hose.	ACME 3/4" x 1/2" BSP.	Forged.
3	Ball Valve Brass Scr.	Forged, Brass EN331 Rated for Gas Working Pressure 25 Kg/Cm ² for manifold	1/2" BSP	Comap/itap/RN/equi
4	LPG Hoses	Hose suitable for Pressures below. EN 857, 1ST/ SAE 100 R1 AT Working Pressure - 180 Bar. Test Pressure - 360 Bar. Burst Pressure - 720 Bar.	1/2" BSP x 3/8" BSP.	Parker/ Super Hose/ Equi.
5	Pipeline (Before Vapouriser)	Sch.40 as per IS: 1239, MS Seamless.	Size: 1"	MST/ ISMT/ Jindal/ Equi.
6	Ball Valves Flanged ends.	Cast Steel Body conforming to ASTM A 215 WCB Body SS balls, Fire Safe Type with operating wrenches. #300/#150	Sizes: 1"	Sankey/equi.
7	Sight Flow Glass	Cast Steel Body, with toughened glass, Hydro-test Pressure: 30 Kg/cm ² , Working Pressure: 15 Kg/cm ² , Operating Temperature: 90°C. Ends flanged to ANSI B 16.5 #300	Size: 1"	CIE/ equi.



8	Non Return Valve	Cast Carbon Steel Body, Internals- Stainless Steel, Horizontal Mounting Lift Check Type, Hydro- test Pressure: 30 Kg/cm ² , Working Pressure: 15 Kg/cm ² , Operating Temperature: 90oC. #300/#150	Size: 1"	Trine/ CIE/ equi.
9	Strainer	Cast Carbon Steel Body (ASTM A-216 Gr. WCB), with SS 304 Screen, Hydro-test Pressure: 30 Kg/cm ² , Working Pressure: 15 Kg/cm ² , Operating Temperature: 90°C. #300	Size: 1"	Trine/ CIE/ equi.
10	Pressure Regulators	Inlet 17 Kg/cm2. Outlet 2-4 Kg/cm2. Flow Capacity 200 Kgs/hour max.	Sizes:1"	Vanaz/ Equi.
11	Pipe Line (After Vapouriser)	MS Class `C' ERW Heavy Duty as per IS 1239.	Sizes: 1"	Asian/Jindal/ Equi.
12	Pressure Gauges	4" Dia 0 to 10 Kgs/cm2	3/8" BSP inlet.	Fair/ Equi.
13	Slam Shut Off Valve	Over Pressure Device set to shut off system at a set pressure.	Inlet / Outlet size 1"	Vanaz/ Equi.
14	Filter	Working Pressure 25Kg/Cm2. Capacity: 150 Kgs/hr Min.	Inlet / Outlet size 1"	Vanaz/ Equi.
15	LPG Vapouriser	PESO Approved	50kg/hr Regular	Anil Engineering



IIM NAGPUR

भारतीय प्रबंध संस्थान नागपुर
Indian Institute of Management Nagpur

16	Liquid Trap	Working Pressure 25Kg/Cm2.	Inlet / Outlet size 1"	Fabricated
17	Ball Valve Brass Scr. For Pressure Gauges	Forged, Brass Working Pressure 10 Kg/Cm2 for Pressure gauge & SRV.	3/8" BSP.	RN/ equiv.
18	Compliance of ISO 6044 should be done for above mentioned work			
19	If any other necessary items are required for setting up LOT type gas bank system mandatory as per concerned regulatory authority, it should be listed in the Technical bid with the copy of documents mentioning the same issued by regulatory authority.			
20	Leak detection alarm system to be setup by bidder.			
21	Additional items if any required to improve efficiency of the system should be listed in the Technical bid and justification for the same should be attached.			

Works in the scope of IIM Nagpur - End user scope

1	Electrical	3 phase electrical connection with 4 core 4sq mm armoured Cu cable & soft water supply line for vaporizer.
2	Cylinders	Supply of cylinders.
3	Civil Work.	Any kind of Civil work for platform and fabrication work for cage.
4	(N.O.C)	No Objection Certificate from local governing authority.
5	Fire Fighting System.	Fire Fighting system.



Kitchen Layout of EEP Dining block for which work is to be done (To be checked Physically by Bidder before Bidding)

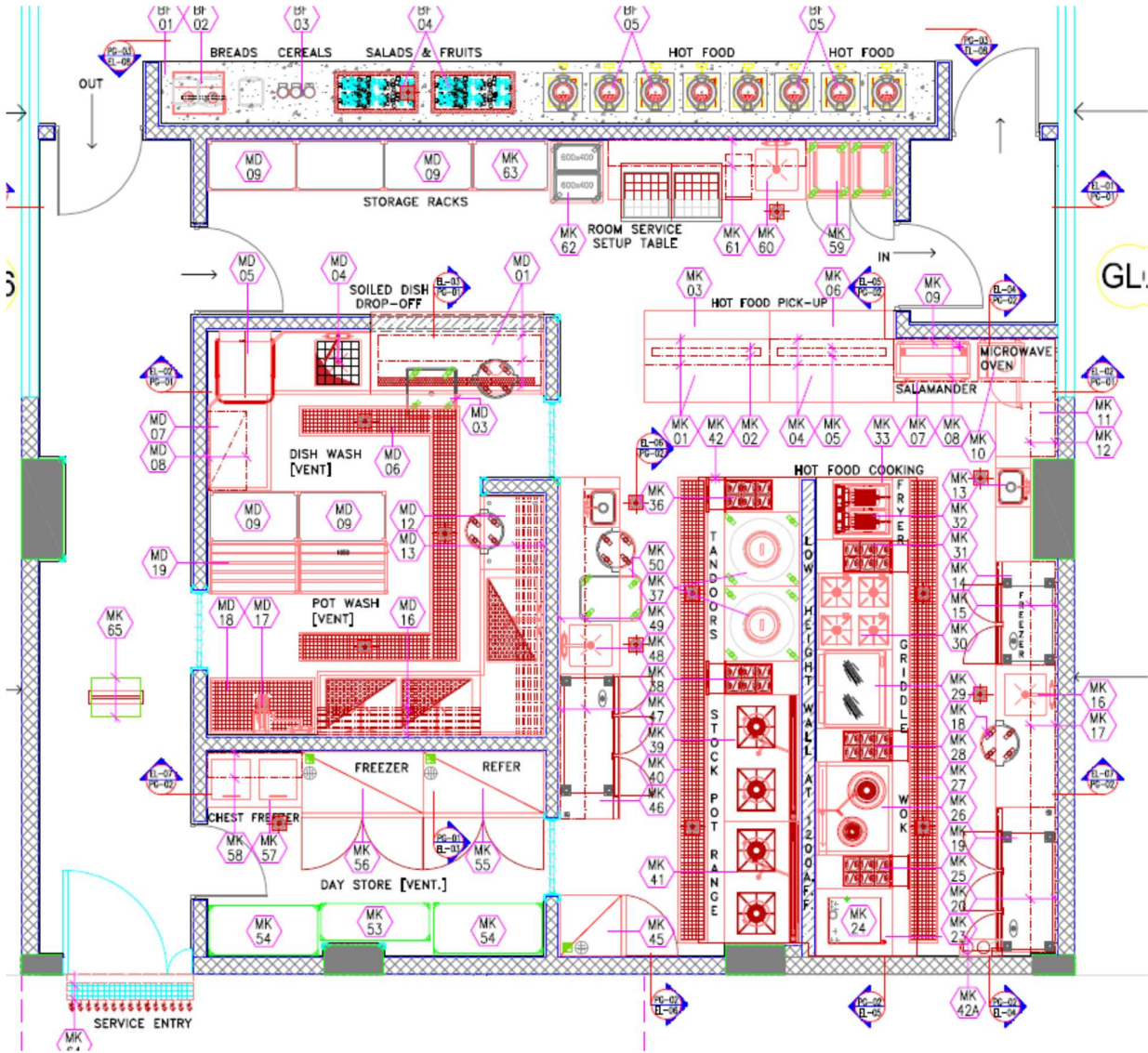



Indicative Layout of Gas bank for S& F Dining Block (Bidders have to submit their own layout proposal and drawings)

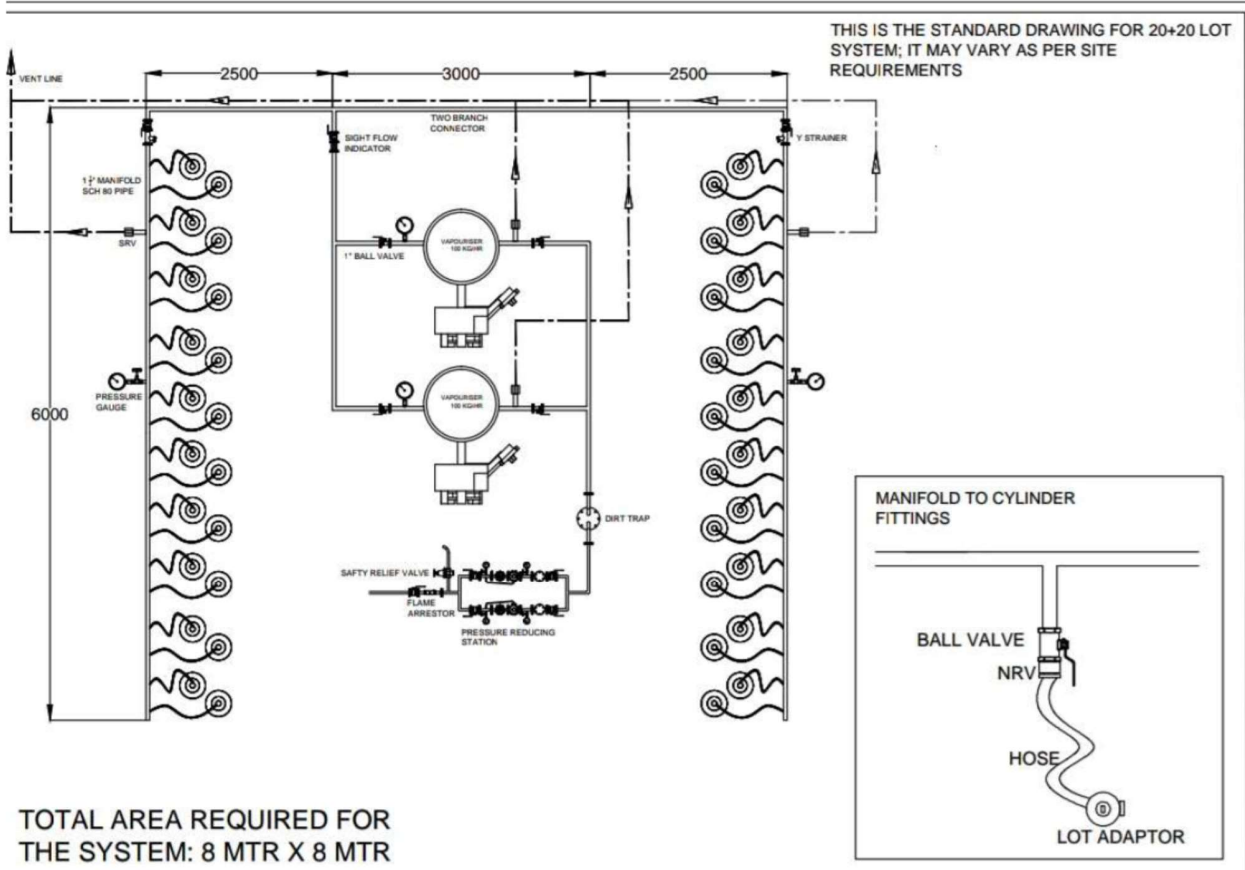



Indicative Layout of Gas bank for EEP Dining Block (Bidders have to submit their own layout proposal and drawings)

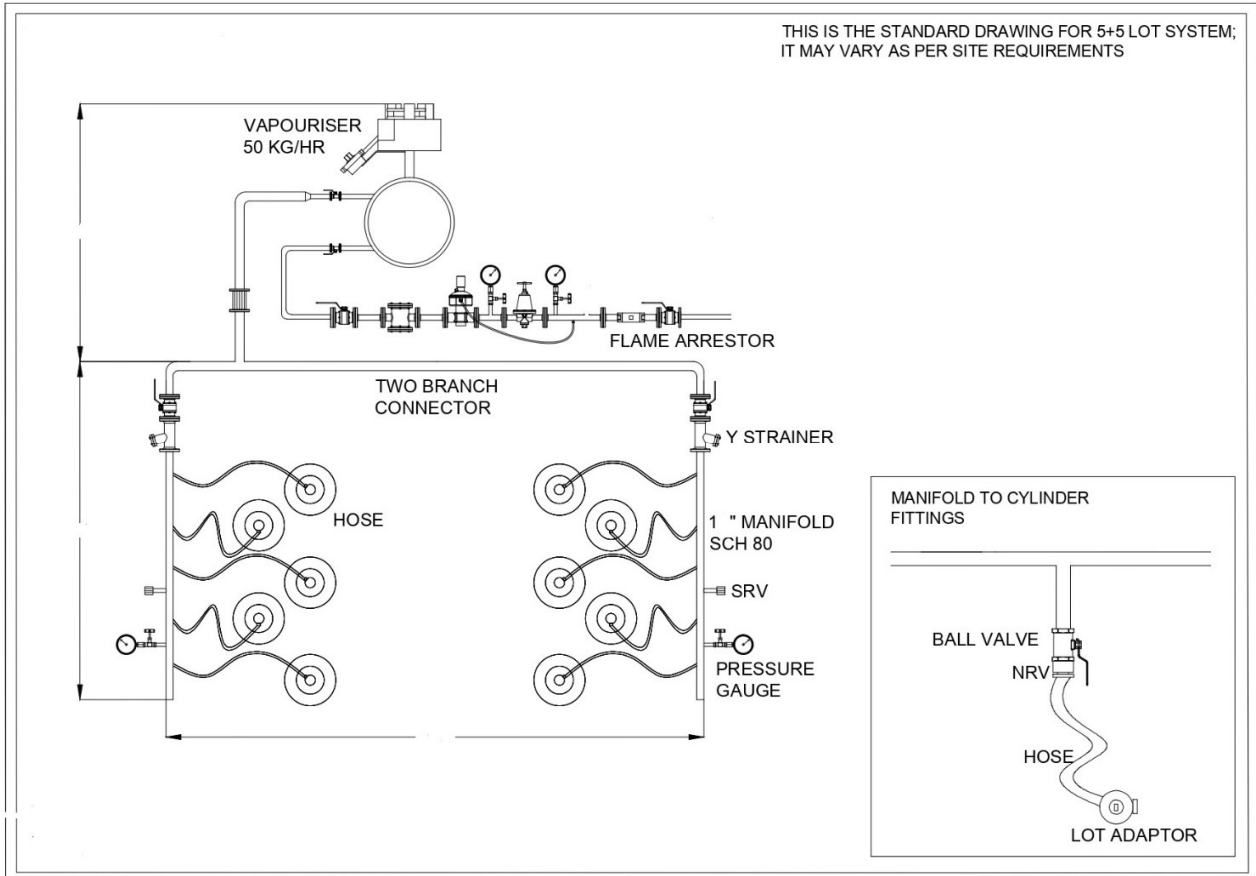



Chapter 4 Technical Bid

The indicative list of components and diagrams are given in the Scope of Work Chapter 3.

The bidders are required to understand the requirements of IIM Nagpur and submit a Technical Bid which they propose as the best system for the works. Based on the proposal, the bidders should submit the list of components with brands and their quantities and proposed schematic diagrams for both the layouts.

Following documents will be part of the Technical Bid.

Enter the Bidder's Name		
Sr.no	Documents	Submitted Yes/No
1	Schematic drawing of LOT type Gas bank system for S&F Dining block at IIM Nagpur, MIHAN campus clearly mentioning the space requirements for the Gas Bank.	
2	List of components used in LOT type Gas bank system for S&F Dining block at IIM Nagpur, MIHAN campus.	
3	Schematic drawing of LOT type Gas bank system for EEP Dining block at IIM Nagpur, MIHAN campus clearly mentioning the space requirements for the Gas Bank.	
4	List of components used in LOT type Gas bank system for EEP Dining block at IIM Nagpur, MIHAN campus.	

**Annexure A****PARTICULARS OF BIDDER**

SR.NO	DESCRIPTION	
1	Name of the bidder	
A	Trade Name (in Block letters)	
B	Status of the Bidder (Proprietorship/Partnership/LLP/Limited Co.) In Block letters)	
2	Postal Address for communication	
3	Telephone No.	
4	E-mail / Website address (if available)	
5	PAN (Enclose self-attested photocopy)	
6	GSTIN (GST Registration No.) (If applicable) (Enclose self-attested photocopy)	

I/We hereby declare and affirm that I/we have read and understood the terms and conditions of this tender/quotation/ NIT as stipulated in the tender notice No IIMN/154/2021-22/15 dated 21/03/2022. Accordingly, I/ we accept the terms and conditions and hereby offer the rates for "Supply, installation and commissioning of LOT type Gas bank system for S&F Dining block, EEP Dining block at IIM Nagpur,MIHAN campus" as per Price Bid.

Signature _____

Date _____

Official seal of bidder _____



FORMAT OF BID SECURITY DECLARATION FROM BIDDERS IN LIEU OF EMD
(On Bidder's Letter head)

I / We, the authorized signatory of M/s , participating in the tender **No. IIMN/154/2021-22/15 dated 21/03/2022** for **Supply, installation and commissioning of LOT type Gas bank system for S&F Dining block, EEP Dining block at IIM Nagpur, MIHAN campus**, do hereby declare:

- (i) That I / we have availed the benefit of waiver of EMD while submitting our offer against the subject Tender and no EMD is being deposited for the said tender.
- (ii) That in the event we withdraw / modify our bid during the period of bid validity or I/we fail to execute formal contract agreement within the given timeline OR I/we fail to submit a Performance Security within the given timeline or I/we commit any breach of Tender Conditions / Contract which attracts penal action of forfeiture of EMD
Then I/we will be suspended from being eligible for bidding / award of all future contract(s) of Indian Institute of Management Nagpur for a period of one year from the date of committing such ~~breach~~

Signature of Authorized Signatory of bidder

Name of Authorized Signatory

Company Name



IIM NAGPUR
भारतीय प्रबंध संस्थान नागपुर
Indian Institute of Management Nagpur

Annexure-C

Sr.no	Year	Annual turnover	Profit & loss
1	2018-19		
2	2019-20		
3	2020-21		

Signature _____

Date _____

Official seal of bidder _____



CHECK LIST OF DOCUMENTS TO BE SUBMITTED

Bidder is required to fill-up this checklist and submit with the PQ and Technical bid:

Sr.no	Description	Compliance YES/NO / Document attached	Bid document Reference
1	Particulars of bidders (Annexure A)		
2	Bid security declaration (Annexure B)		
3	PAN		
4	GST Registration		
5	Proof of authorized dealership		
6	Proofs of bidder as per Eligibility criteria Chapter 2		
7	Technical Bid as per Chapter 4		
8	The annual turnover of the firm in last three consecutive financial years as on 31.03.2021 (For FY 2018-19, 2019-20,2020-21) shall be minimum Rs: 10 lakh Annexure C		
9	Undertaking – Not blacklisted from any government organization		

I/We hereby declare and affirm that I/we have read and understood the scope of work as per Chapter 3 of the tender notice No IIMN/154/2021-22/15 dated 21/03/2022. Accordingly, I/ we hereby offer the above products and the rates for the same are quoted in the Price Bid.

Signature _____

Date _____

Official seal of bidder _____



Part-2

Price Bid

Tender No: IIMN/154/2021-22/15 dated 21/03/2022
(To be submitted in separate envelope)

NAME OF WORK : Supply, installation and commissioning of LOT type Gas bank system for S&F Dining block and EEP Dining block at IIM Nagpur, MIHAN campus.

Enter the Bidder's Name					
Sr.no	Description of work	Quantity	Rate	GST %	Amount
1	Supply, installation and commissioning of LOT type Gas bank system for S&F Dining block at IIM Nagpur, MIHAN campus as per Technical Bid submitted.	1			
2	Supply, installation and commissioning of LOT type Gas bank system for EEP Dining block at IIM Nagpur, MIHAN campus as per Technical Bid submitted.	1			
Total Amount including Freight/Transit Insurance/Installation and all Taxes:					

Total Amount in words (including GST) - _____

Name of Bidder -

Signature -

Seal -

Note- Work will be awarded on the overall lowest amount quoted for Sr. no.1 and Sr. no.2